

SOFT-FAULT DIAGNOSIS OF ANALOG CIRCUIT WITH TOLERANCE USING FNLP

Wei Zhang¹⁾, Longfu Zhou^{1,3)}, Yibing Shi¹⁾, Chengti Huang^{1,2)}, Yanjun Li¹⁾

1) University of Electronic Science and Technology of China, School of Automation Engineering, No.2006, Xiyuan Road, High Technology District, Chengdu 611731, Sichuan, China (✉ weizhang@uestc.edu.cn, +86 28 6183 0582, ybshi@uestc.edu.cn, yjli@uestc.edu.cn)

2) University of Notre Dame, Department of Electrical Engineering, 275 Fitzpatrick Hall, Notre Dame, 46556, IN, USA (chuang5@nd.edu)

3) Department of Information, the 452nd Hospital of PLA, No.1, Gongnongyuan Road, Jingjiang District, Chengdu 610061, Sichuan, China (zhoulf_1977@163.com)

Abstract

A new soft-fault diagnosis approach for analog circuits with parameter tolerance is proposed in this paper. The approach uses the fuzzy nonlinear programming (FNLP) concept to diagnose an analog circuit under test quantitatively. Node-voltage incremental equations, as constraints of FNLP equation, are built based on the sensitivity analysis. Through evaluating the parameters deviations from the solution of the FNLP equation, it enables us to state whether the actual parameters are within tolerance ranges or some components are faulty. Examples illustrate the proposed approach and show its effectiveness.

Keywords: analog circuit, fault diagnosis, sensitivity, fuzzy, nonlinear linear programming.

© 2010 Polish Academy of Sciences. All rights reserved

I. Introduction

Since the 1970's, with the rapid development of electric industry, testing and diagnosis play an important role for the development of the industry. It is estimated that testing can account for up to 30% of the total manufacturing cost [1] in 1993. In [2], it is reported that 95% of the test cost in mixed-signal circuits is expended in testing the analog parts. Therefore, the research on the diagnosis of analogue circuit has become one of hot topics. Many methods have been proposed for fault diagnosis in analogue circuits [3–16]. Among all those methods, linear programming is one of them. Reference [5] uses a linear programming technique to isolate the elements most likely to be faulty under the limited definition of an error parameter for every network element. Reference [6] utilizes the l_1 norm to isolate possible faulty elements and the linear programming as a solving tool. In [7], a new method based on linear programming is described for calculating the ranges of values in the diagnosis equations. Two related algorithms [8–9] employ mini-max linear programming techniques to generate DC and AC tests to detect structural faults. Reference [10] extends the method in [6] to nonlinear circuits. In reference [11], through checking the existence of a feasible solution of linear programming equation, a soft-fault is located in a linear and nonlinear circuit. During the diagnosis process in [11], each element's parameter changing range should be changed in order to decide whether the element is faulty, which make the time spent in diagnosing a fault very long. The method is a qualitative method. Reference [12] combines a fuzzy identification methodology with some ideas from linear programming theory. In reference [13], a node-voltage sensitivity sequence dictionary is established to detect any fault of any component using one fault characteristic code. Reference [14] gives an approach of combined sensitivity analysis and fuzzy analysis to diagnose a soft fault in linear analog circuits. However, the definition of fault set and membership function is open to suspicion. In [15], a new dictionary

approach using the slope of voltage increment in two nodes as fault character for the diagnosis of both soft-fault and hard-fault is introduced. Based on basic features calculated from a circuit under the test's time domain response to a voltage step, reference [16] gives a testing process for analog circuit using artificial neural network.

Although many methods using single linear programming [5–15] for fault diagnosis have been developed, those methods are mostly focused on the qualitative diagnosis of the circuit. In other words, all those methods in [5–15] are to locate the position of the faulty element in the circuit and they are unable to estimate the parameter perturbation of the faulty element. How to diagnose a circuit quantitatively is still a subject in the field of analog circuit diagnosis.

In this paper, an approach of soft-fault diagnosis is proposed using the fuzzy nonlinear programming (FNLP) concept [17–19]. The work of both identification of faulty elements and evaluation of their parameters deviations are performed together here. The objective of this FNLP equation is to find the minimum value of each parameter from zero which satisfies all those constraints and the constraints equations are actually the voltage increment equations in all test nodes and the changing range of each element.

The paper is organized as follows. Section 2 presents the composition of constraint equations based on node-voltage sensitivity analysis in fault diagnosis. The diagnosis methodology based on FNLP is provided in Section 3. In Section 4, experimental results are given to show the effectiveness of the proposed method and a comparison with other methods. Conclusions are summarized in Section 5.

2. Node-voltage sensitivity analysis

In this section, the fundamental theory of node-voltage sensitivity analysis to compose the constraint equations in our diagnosis approach is discussed.

A circuit under test (CUT) with n elements will be represented by the node equations with the node-voltage vector $e = [e_1, e_2, \dots, e_m]^T$, where m is the number of nodes accessible for measurement.

2.1. The Definition of Node-voltage Sensitivity

In [13], the partial derivative of a node voltage with respect to a component parameter is called the node-voltage sensitivity, which is denoted as:

$$S_{Y_i}^{e_j} = \frac{\partial e_j}{\partial Y_i}, (i = 1, 2, \dots, n; j = 1, 2, \dots, m), \quad (1)$$

where e_j is the node voltage of node j and Y_i is i -th component's parameter. Generally, Y_i are G, R, C, L or the control parameters for dependent sources.

2.2. Node-voltage increment equations for DC circuits

Suppose that the admittance of the element connected to nodes k and q has been perturbed from Y_{kq} to $Y_{kq} + \Delta Y_{kq}$. This causes the node-voltage perturbations from e to $e + \Delta e$. In [11], it is shown that the deviation of the j -th node voltage Δe_j is given by:

$$\Delta e_j = -\left(z_{jk} - z_{jq}\right) \frac{\Delta Y_{kq}}{1 + \delta \Delta Y_{kq}} (e_k - e_q), \quad (2)$$

where, z_{jk}, z_{jq} ($j = 1, \dots, m$) are elements of the node impedance matrix and:

$$\delta = z_{kk} - z_{kq} - z_{qk} + z_{qq}.$$

If $\Delta Y_{kq} \rightarrow 0$, from (2), it can be led to:

$$\frac{\partial e_j}{\partial Y_{kq}} = -(z_{jk} - z_{jq})(e_k - e_q). \quad (3)$$

Likewise, it is achieved that:

$$\frac{\partial e_j}{\partial K} = -(z_{jk} - z_{jq})(e_r - e_s), \quad (4)$$

where K is the gain of the controlled source (VCCS, etc.) connected to nodes k and q , with controlling variable v_{rs} between nodes r and s .

Hence, the variation Δe_j caused by perturbation from the nominal values of all the parameters is approximately given by:

$$\Delta e_j = \sum_{n_y} S_{Y_i}^{e_j} \Delta Y_i + \sum_{n_K} S_{K_i}^{e_j} \Delta K_i, \quad (5)$$

where the summation includes all elements in the circuit.

Therefore, the Eq. (6) can be obtained:

$$u_j = \sum_{i=1}^n a_{ij} p_i, \quad (6)$$

where u_j represents the voltage increment in j -th measured node and p_i is a variation of i -th element parameter whereas a_{ij} is a constant sensitivity coefficient from the i -th element to j -th measured node.

2.3. Node-voltage increment equations for AC circuits

In linear AC circuits, the quantities u_j and the AC sensitivity coefficients a_{ij} are generally complex. Thus, Eq. (6) will be decomposed into two parts (real part and imaginary part) so that all coefficients and quantities are real.

$$\operatorname{Re}(u_j) = \sum_{i=1}^n \operatorname{Re}(a_{ij}) p_i, \operatorname{Im}(u_j) = \sum_{i=1}^n \operatorname{Im}(a_{ij}) p_i. \quad (7)$$

Performing decomposition of (7) for each measurement node, the equation groups to any measurement node are obtained as follows:

$$\begin{aligned} u_{j_1} &= \sum_{i=1}^n a_{ij_1} p_i \\ u_{j_2} &= \sum_{i=1}^n a_{ij_2} p_i \end{aligned} \quad (j = 1, 2, \dots, m), \quad (8)$$

where: $u_{j_1} = \operatorname{Re}(\Delta e_j)$, $u_{j_2} = \operatorname{Im} g(\Delta e_j)$, $a_{ij_1} = \operatorname{Re}(a_{ij})$, $a_{ij_2} = \operatorname{Im} g(a_{ij})$.

3. Fault detection

In this section, the building of a FNLP equation for diagnosis of the CUT is discussed.

3.1. Diagnosis Equation

Because the perturbation of node-voltage in any test node from its nominal value is a linear function of those error parameters, the diagnostic problem can be considered as finding the result of an underdetermined system with linear equations on the condition that all the solution will have the minimum number of error parameters different from zero.

So, diagnostic equations can be formulated according to (6), expressing node-voltage perturbations u_j in terms of parameter variations p_i . However, because the unrestricted variable p_i is allowed to take on positive or negative values, it must be substituted by using the substitution $p_i = p_i^+ - p_i^-$, where p_i^+, p_i^- are both non-negative. Intuitively if the variable p_i is positive then p_i^+ is positive and p_i^- is zero, while if the variable p_i is negative then p_i^+ is zero and p_i^- is positive. If p_i is zero, then p_i^+, p_i^- obviously are both zero.

So,

$$u_j = \sum_{i=1}^n a_{ij} p_i^+ - \sum_{i=1}^n a_{ij} p_i^-, (j = 1, 2, \dots, m), \quad (9)$$

where $p_i^+ \geq 0, p_i^- \geq 0$.

Suppose there are k test nodes in CUT, an equation set can be built as in (10).

$$\begin{cases} u_1 = \sum_{i=1}^n a_{i1} p_i^+ - \sum_{i=1}^n a_{i1} p_i^- \\ u_2 = \sum_{i=1}^n a_{i2} p_i^+ - \sum_{i=1}^n a_{i2} p_i^- \\ \vdots \\ u_k = \sum_{i=1}^n a_{ik} p_i^+ - \sum_{i=1}^n a_{ik} p_i^- \end{cases}, \quad (10)$$

$$\Rightarrow \quad b = [A \vdots -A] \begin{bmatrix} P^+ \\ P^- \end{bmatrix}, \quad (11)$$

where:

- $A = [a_{ij}]_{n \times k}^T$;
- $b = [u_1, \dots, u_k]^T$;
- $P^+ = [p_1^+, \dots, p_n^+]^T$;
- $P^- = [p_1^-, \dots, p_n^-]^T$.

Furthermore, a key question is to find a feasible solution to the above formulated problem. In reference [11], the linear-programming with phase 1 of the simplex method concept is used to answer the question. But in [11], the method requires the analysis of two circuits which differ in excitations one from another. For identification of a single faulty element in CUT, the tolerance limit of every element must be changed in turn and the diagnosis equation must be reformulated as well. When there are multi-faults in the CUT, the method in [11] becomes even more complicated because it needs to select a multi-element set from all candidate

elements, which is inconvenient for a large circuit. At the same time, the method just identifies the faulty elements qualitatively and cannot determine their parameter variations. In this paper, in order to overcome the questions mentioned above, the concept of FNLP is introduced to locate the faulty elements and identify their perturbed values.

How to formulate the diagnosis problem as a standard mathematical programming is not always obvious. It is quite evident that unconstrained optimization formulation is not suitable since there is always a set of performance constraints and constraints on parameter size limitations. A single objective optimization formulation is very restrictive because only one objective is optimized at a time, and it has to be decided which objective to optimize. The nearest mathematical programming formulation to the diagnosis problem is the following:

$$\text{Minimize } \begin{cases} f_1(p) = p_1^+ \\ f_2(p) = p_1^- \\ \vdots \\ f_{2n-1}(p) = p_n^+ \\ f_{2n}(p) = p_n^- \end{cases}, \quad (12a)$$

$$\text{Subject to } \begin{cases} [A \ : \ -A]P = b \\ P_{\min} \leq P \leq P_{\max} \end{cases}, \quad (12b)$$

where $P = \begin{bmatrix} P^+ \\ P^- \end{bmatrix}$, A , b , P^+ and P^- are defined as in equation (11). In Eq. (12), $f_i(p)$ are $2n$ objective functions to be minimized; $[A \ : \ -A]P = b$ are constraints to be satisfied; P is the vector of element parameters, and $P_{\min} \leq P \leq P_{\max}$ are bounding conditions on the element parameters.

The object function $f_i(p)$ represents the parameter variations of each element in CUT. In a non-faulty circuit with tolerance influence, all element parameter perturbations are small and they are below their tolerance range. From the definition of node-voltage sensitivity analysis in Section 2, the voltage value in tested nodes and element parameter perturbation are satisfying the constrained function. So the Eq. (12) can be built.

For our purposes, the diagnosis of an analog circuit consists in assigning values to a set P of parameters so that the circuit meets objectives while satisfying a set of performance specifications.

3.2. Fuzzy Objectives

In an industrial environment, during modeling the diagnosis problem as in (12), we force the tester to state his problem in precise mathematical terms rather than in terms of the real world which are often imprecise by nature.

In fact, objectives are often better expressed in real-world terms than in precise numbers. Testers often use terms like minimize, small, very large, substantially higher than, *etc.*, to state their diagnosed objectives. These terms have a fuzzy meaning and are difficult to express precisely by numbers. Fuzzy set theory makes it possible to quantify and manipulate such human statements [19].

In the attempt to minimize a performance function $f_i(p)$, testers often stop the search procedure when $f_i(p)$ attains acceptable values, even before the strict minimum is reached. Additional searching may be very time-consuming with no significant improvement in the objective function. For this reason, we associate with each objective a function $f_i(p)$. In (12), a fuzzy set that formulates the fuzzy meaning of minimize (or maximize) and what precisely the tester wants to achieve.

For each fuzzy objective $f_i(p)$, we define a membership function μ_{f_i} which associates with each value $f_i(p)$ of the objective function a grade of membership μ_{f_i} reflecting the degree of acceptability of that particular performance value. If D_{f_i} is the interval of possible values of $f_i(p)$, μ_{f_i} will be defined as follows:

$$\begin{aligned} \mu_{f_i} : D_{f_i} &\rightarrow [0,1] \\ f_i(p) &\rightarrow \mu_{f_i}(p) \end{aligned} \quad (13)$$

μ_{f_i} is a real number in $[0, 1]$ reflecting the degree of fulfillment of the fuzzy objective associated with the objective function f_i . $\mu_{f_i}(p) = 1$ means that the objective function f_i is fully satisfied, while $\mu_{f_i}(p) = 0$ means that f_i is not satisfied at all; this will occur when $f_i(p)$ takes an unacceptable value. An intermediate value will reflect the acceptability of that particular performance value. It is clear that the closer $\mu_{f_i}(p)$ is to 1 the better the solution.

Let suppose that:

- U_i – the maximum value of the i -th element's parameter;
- L_i – the minimum value of the i -th element's parameter;
- $d_i = U_i - L_i$: the changing range of the i -th element's parameter.

For elements in CUT, the worst faults are open and short. If an element in CUT is open, parameter variations p_i^+ is $+\infty$. And if an element in CUT is shorted, parameter variations p_i^- is Y_i , where Y_i is i -th element's nominal parameter. And, in the calculation process, $100Y_i$ is used to represent the "open" state of the element. So, to the i -th element in CUT, if the parameter of the element increases, the parameter variations p_i^+ is defined in the range $[0, 100Y_i]$, which means that the maximum value U_i to p_i^+ is defined as $100Y_i$; if the parameter of the element decreases, the parameter variations p_i^- will be in the range $[0, Y_i]$ and the maximum value U_i to p_i^- is equal to the element's nominal parameter. The minimum L_i value of the i -th element, to both p_i^+ and p_i^- , are actually defined as 0.

So, to every element in the CUT, a fuzzy membership function [20] could be defined as $\mu_i(p)$.

$$\mu_i(p) = \begin{cases} 1 & 0 \leq p_i \leq L_i \\ \frac{U_i - p_i}{d_i} & L_i < p_i < U_i \\ 0 & p_i \geq U_i \end{cases} \quad (14)$$

Obviously, when $p_i = U_i$, $\mu_i(p) = 0$ and when $p_i = L_i$, $\mu_i(p) = 1$. An example of a membership function, for the fuzzy objective to minimize $f_i(p)$, is shown in Fig. 1.

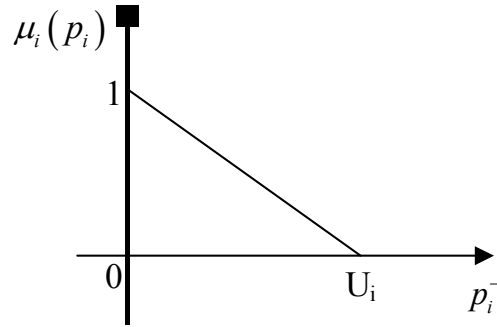

Fig.1. Membership function for the fuzzy objective minimize.

3.3. Building of FNLP Equation

After the objectives are fuzzyfied and after the corresponding membership functions are defined, the diagnosis problem in (12) becomes:

$$\begin{aligned} & \text{Maximize } \{ \mu_{f_1}, \mu_{f_2}, \dots, \mu_{f_M} \} \\ & \text{Subject to } [A : -A]P = b \\ & \quad P_{\min} \leq P \leq P_{\max} \end{aligned} \quad (15)$$

Therefore, to any solution of the formula (9), it is hoped that $\mu_i(p)$ achieves the maximum value or elements' parameter perturbations are being minimum. So another variable λ is introduced:

$$\begin{aligned} & \text{Maximize } \lambda \\ & \text{Subject to } \lambda \leq \frac{U_i - p_i}{d_i} \end{aligned} \quad (16)$$

For this purpose, a FNLP equation, tending to satisfy the constraints, namely (9), with the minimum number differing from zero, is constructed.

The FNLP equation can be formally stated as follows.

$$\begin{aligned} & \text{Maximum } \lambda \\ & \text{Subject to } [A : -A]X = b \end{aligned} \quad (17a)$$

$$\lambda \leq \frac{U_i - p_i^+}{d_i},$$

$$\lambda \leq \frac{U_i - p_i^-}{d_i},$$

$$p_i^+ \cdot p_i^- = 0 \quad (i = 1, 2, \dots, n), \quad (17b)$$

where:

$$- A = [a_{ij}]_{n \times m}^T;$$

$$- b = [u_1 \dots u_m]^T;$$

$$\begin{aligned}
 - \quad X^+ &= [p_1^+ \cdots p_n^+]^T; \\
 - \quad X^- &= [p_1^- \cdots p_n^-]^T; \\
 - \quad X &= \begin{bmatrix} X^+ \\ X^- \end{bmatrix}.
 \end{aligned}$$

Using the initial solution generated by the first-cut sizing procedure, the optimization problem (17) is solved with a feasible direction algorithm [21]. Note that the algorithm used is a local one. However, this is not a real limitation of the approach since the final fuzzy formulation obtained in (17) is independent from the resolution algorithm and therefore can be solved using a more powerful nonlinear programming algorithm, in addition designers often accept a local minimum.

When there are faulty elements in CUT, the nonzero values of X are connected across their corresponding elements. From the output of the FNLP equation, we obtain the solving vector X , which represents the deviation in each element value. After checked against their assigned tolerance value, if the change exceeds the allowed tolerance, it can be declared that the element is faulty, otherwise it is un-faulty. So, in the method, not only the faulty elements are located but the parameter perturbed values are identified quantitatively.

4. Examples of the new method for fault location and identification

In this Section, two examples for both DC and AC circuit are given to illustrate the method for fault detection and identification of the faulty elements' deviational values developed in Sections 2 and 3. Another example is given to show the method's efficiency compared with other methods in reference [14]. All simulation work is finished in a PC with 1.73 GHz, 512 MB and the PSPICE program is used as the circuit simulator and LINGO program is used to solve the FNLP equation.

4.1. Diagnosis example for a DC circuit

Let us consider the linear DC circuit depicted in Fig. 2 where we assume that nodes 1, 2 and 3 are accessible for measurement. The nominal parameters are shown in Fig. 2. The tolerance of any element is 5% of its nominal value. Thus, to this circuit, a DC sensitivity coefficient matrix from each element in the CUT to test points is built as A .

As mentioned in 3.1, based on the sensitivity coefficient matrix A and the measured voltage value in test nodes, a diagnosis equation as in Eq. (12) can be built. Then, from the nominal value of each element in circuit, the value of U_i , L_i and d_i can be decided. To this point, a FNLP equation as in Eq. (17) can be built. In the end, from the solution of the equation, whether the CUT is faulty and which element is faulty are both decided.

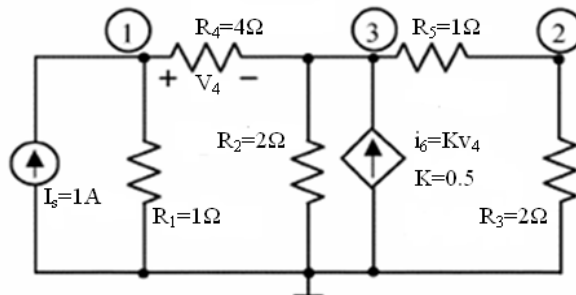

Fig. 2. A linear dc circuit.

$$A = \begin{matrix} & R_1 & R_2 & R_3 & R_4 & R_5 & K \\ \begin{matrix} 1 \\ 2 \\ 3 \end{matrix} & \begin{bmatrix} 0.781 & 0.015 & 0.006 & 0.022 & 0.065 & 0.062 \\ 0.247 & 0.049 & 0.068 & -0.005 & -0.071 & 0.205 \\ 0.367 & 0.073 & 0.032 & -0.008 & 0.032 & 0.307 \end{bmatrix} \end{matrix}$$

The CUT is tested with bias point analysis by inducing faults to the circuit in the component value from the nominal value. Five cases are considered and the method for fault detection developed in Section 3 is applied every time.

Case 1. The actual parameters are: $R_1 = 1.03\Omega$, $R_2 = 2\Omega$, $R_3 = 1.96\Omega$, $R_4 = 4\Omega$, $R_5 = 1\Omega$, $K = 0.48$. All the parameters are within the tolerance ranges.

Case 2. The actual parameters are: $R_1 = 1\Omega$, $R_2 = 2\Omega$, $R_3 = 2\Omega$, $R_4 = 3.7\Omega$, $R_5 = 1.05\Omega$, $K = 0.5$, the parameter R_4 slightly exceeds the tolerance range and R_5 is in the maximum value within its tolerance range whereas all the other elements are in their nominal values.

Case 3. The actual parameters are: $R_1 = 1.17\Omega$, $R_2 = 2.08\Omega$, $R_3 = 2\Omega$, $R_4 = 3.85\Omega$, $R_5 = 0.98\Omega$, $K = 0.51$, the element R_1 is faulty and all the other elements are within their tolerance ranges.

Case 4. The actual parameters are: $R_1 = 1.28\Omega$, $R_2 = 2.08\Omega$, $R_3 = 2.63\Omega$, $R_4 = 4\Omega$, $R_5 = 0.98\Omega$, $K = 0.51$, the elements R_1 and R_3 are faulty and all the other elements are within their tolerance ranges.

Case 5. The actual parameters are: $R_1 = 1.28\Omega$, $R_2 = 2.08\Omega$, $R_3 = 2.63\Omega$, $R_4 = 5.26\Omega$, $R_5 = 0.98\Omega$, $K = 0.51$, the elements R_1 , R_3 and R_4 are faulty and all the other elements are within their tolerance ranges.

The global optimal solution of the FNLP equation is shown in Table 1.

Table 1. The solution of the linear DC circuit.

	Case1	Case2	Case3	Case4	Case5
$\Delta R_1(\Omega)$	-0.8905E-06	-0.3571E-06	0.1606	0.2732	0.2966
$\Delta R_2(\Omega)$	0.7068E-01	0.0000	0.0000	0.0000	0.0000
$\Delta R_3(\Omega)$	0.9251E-01	0.0000	0.4559E-01	0.7342	0.7237
$\Delta R_4(\Omega)$	0.9074 E-01	-0.3156	0.0000	0.0000	0.7517
$\Delta R_5(\Omega)$	0.6776E-01	0.5052E-01	0.0000	0.0000	0.0000
ΔK	0.0000	0.0000	0.3742E-01	<i>0.2965E-01</i>	0.0000

Now we consider the calculated results and compare the value in the solution of the equation with their tolerance ranges. The results are as follows.

Case1. All the values in the solution of the equation are within elements' tolerance ranges. Hence, the circuit is non-faulty.

Case 2. The value of ΔR_4 is heavily beyond its tolerance range meanwhile the value of ΔR_5 slightly exceeds its tolerance range. Considering the influence of calculation error, it can be thought that R_4 in the CUT is faulty.

Case 3. The value of ΔR_1 is beyond its tolerance range, which means R_1 in the CUT is faulty.

Case 4. The values of ΔR_1 and ΔR_3 are heavily beyond their tolerance ranges and the parameter ΔK slightly exceeds its tolerance range. As in Case 2, it can be thought that R_1 and R_3 in the CUT are faulty.

Case 5. The values of ΔR_1 , ΔR_3 and ΔR_4 are heavily beyond their tolerance ranges, so R_1 , R_3 and R_4 in the CUT are faulty.

4.2. Diagnosis example for an AC circuit

Let us consider a low-pass filter shown in Fig. 3. The nominal parameters are shown in Fig. 3 and the tolerance of any element is 5% of its nominal value. The circuit is driven by an AC voltage source $V_s(t) = \sin 6280t$ V. Below, we consider three cases and every time apply the method for fault detection developed in Section III. We assume that the output node of the CUT is accessible for measurement.

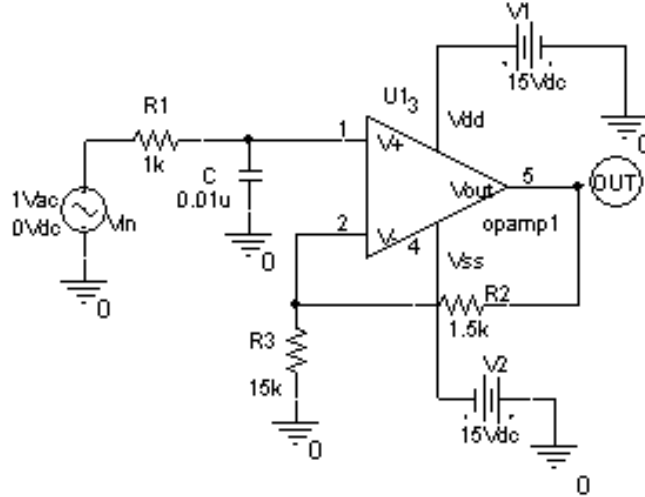

Fig. 3. A low-pass filter.

Case 1. The actual parameters are $R_1 = 1.005\text{k}\Omega$, $R_2 = 1.501\text{k}\Omega$, $R_3 = 14.998\text{k}\Omega$, $C = 0.0101\ \mu\text{F}$. All the parameters are within the tolerance ranges.

Case 2. One element is faulty and the actual parameters are $C = 0.02\ \mu\text{F}$ whereas all the other elements are in their nominal values.

Case 3. One element is faulty and the actual parameters are $C = 0.02\ \mu\text{F}$. The remaining parameters are as in Case 1.

In Table 2, the global optimal solution of the FNLP equation is given.

Table 2. The solution of the linear AC circuit.

	Case1	Case2	Case3
$\Delta R_1(\Omega)$	0.0000	0.0000	0.0000
$\Delta R_2(\Omega)$	1.1826	0.0000	0.0000
$\Delta R_3(\Omega)$	0.0000	0.6423E+03	0.6431E+03
$\Delta C(\mu\text{F})$	0.0000	0.9883E-02	0.9981E-02

Having seen the calculated results from Table 2 and compared the values with their tolerance ranges, the diagnosis results are as follows.

In Case 1, the calculated result states that all the values in the solution of the equation are within elements' tolerance ranges. Hence, the circuit is non-faulty.

In Case 2 and Case 3, only the value of ΔC is out of the tolerance range and other solutions are within their tolerance ranges. Hence, C in the CUT is faulty in the two cases.

Seen from the diagnosed results shown in Table 2, the three per-set single faults in the circuit can be diagnosed correctly by using the methods proposed in the paper. The diagnosed results mean that the method proposed in the paper is still effective for an AC circuit.

4.3. Diagnosis Example Compared with Other Methods

A method using fuzzy theory to diagnose soft fault of a CUT is introduced in reference [14], which defines a fault set and uses the membership function to locate a faulty element.

However, in the reference [14], each fault state is defined as the faulty element is in a fixed value, which make its fault set infinite. And, according to reference [14], the twice or half of the nominal sensitivity ratio is chosen to calculate parameter k in the membership function, which cannot show clearly whether an element's value is out of its tolerance range. Therefore, when a faulty element's value changes heavily and in some condition, incorrect fault location is appearing unavoidably.

In [14], the circuit shown in Fig. 4 is simulated to show the method's effect. In order to show the effectiveness of the method introduced in this paper, some simulation is done using the two methods.

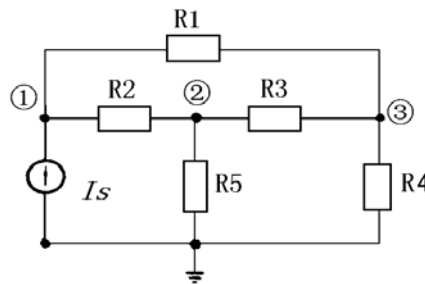

Fig.4. A linear resistive analog circuit

In Fig. 4, $R_1 = R_2 = R_3 = R_4 = 1\Omega$, $R_5 = 0.5\Omega$, $I_s = 1A$. The tolerance limit is 10% and submits to the Gauss distribution.

The diagnosed results using the method given in [14] and this paper for soft fault in R_1 are given in Table 3. For each faulty state of R_1 , 20 Monte-Carlo analyses are done.

Table 3. The diagnosis results of fault in R_1 using method in reference [14] and this paper.

Number	$R_1=0.5\Omega$		$R_1=1\Omega$		$R_1=2\Omega$		$R_1=5\Omega$		$R_1=100\Omega$	
	Result1	Result2	Result1	Result2	Result1	Result2	Result1	Result2	Result1	Result2
(1)	R_1	$R_1 \searrow$	$R_1 / R_3 / R_5$	No fault	R_1	$R_1 \nearrow$	R_1	$R_1 \nearrow$	R_1	$R_1 \nearrow$
(2)	R_1	$R_1 \searrow$	R_5	No fault	R_1	$R_1 \nearrow$	R_1	$R_1 \nearrow$	R_4	$R_1 \nearrow R_2 \nearrow$
(3)	R_1	$R_1 \searrow R_4 \nearrow$	R_5	$R_3 \nearrow$	R_1	$R_1 \nearrow R_2 \nearrow$	R_1	$R_1 \nearrow R_2 \nearrow$	R_4	$R_1 \nearrow$
(4)	R_1	$R_1 \searrow$	R_5	No fault	R_1	$R_1 \nearrow$	R_1	$R_1 \nearrow$	R_5	$R_1 \nearrow$
(5)	R_1	$R_1 \searrow$	R_4	No fault	R_1	$R_1 \nearrow$	R_1	$R_1 \nearrow$	R_1	$R_1 \nearrow$
(6)	R_1	$R_1 \searrow$	R_5	No fault	R_5	$R_1 \nearrow$	R_5	$R_1 \nearrow$	R_4	$R_1 \nearrow$
(7)	R_1	$R_1 \searrow$	R_5	No fault	R_1	$R_1 \nearrow$	R_1	$R_1 \nearrow$	R_1	$R_1 \nearrow$
(8)	R_1	$R_1 \searrow R_4 \nearrow$	R_5	$R_3 \nearrow$	R_1	$R_1 \nearrow$	R_1	$R_1 \nearrow$	R_4	$R_1 \nearrow$
(9)	R_1	$R_1 \searrow$	R_5	No fault	R_1	$R_1 \nearrow$	R_1	$R_1 \nearrow$	R_4	$R_1 \nearrow$
(10)	R_1	$R_1 \searrow$	R_5	No fault	R_1	$R_1 \nearrow$	R_1	$R_1 \nearrow$	R_4	$R_1 \nearrow R_2 \nearrow$
(11)	R_1	$R_1 \searrow$	R_5	No fault	R_5	$R_1 \nearrow$	R_5	$R_1 \nearrow$	R_1	$R_1 \nearrow$
(12)	R_1	$R_1 \searrow$	R_5	No fault	R_1	$R_1 \nearrow$	R_1	$R_1 \nearrow$	R_4	$R_1 \nearrow R_2 \nearrow$
(13)	R_1	$R_1 \searrow$	R_4	No fault	R_1	$R_1 \nearrow$	R_5	$R_1 \nearrow$	R_4	$R_1 \nearrow$
(14)	R_1	$R_1 \searrow R_4 \nearrow$	R_5	No fault	R_5	$R_1 \nearrow R_2 \nearrow$	R_5	$R_1 \nearrow R_2 \nearrow$	R_1	$R_1 \nearrow$
(15)	R_1	$R_1 \searrow R_4 \nearrow$	R_5	No fault	R_1	$R_1 \nearrow R_2 \nearrow$	R_5	$R_1 \nearrow R_2 \nearrow$	R_4	$R_1 \nearrow R_2 \nearrow$
(16)	R_1	$R_1 \searrow$	R_5	No fault	R_5	$R_1 \nearrow$	R_5	$R_1 \nearrow$	R_4	$R_1 \nearrow$
(17)	R_1	$R_1 \searrow$	R_5	No fault	R_5	$R_1 \nearrow R_2 \nearrow$	R_1	$R_1 \nearrow R_2 \nearrow$	R_4	$R_1 \nearrow$
(18)	R_1	$R_1 \searrow$	R_5	No fault	R_1	$R_1 \nearrow$	R_1	$R_1 \nearrow$	R_4	$R_1 \nearrow R_2 \nearrow$
(19)	R_1	$R_1 \searrow$	R_5	No fault	R_1	$R_1 \nearrow$	R_5	$R_1 \nearrow$	R_4	$R_1 \nearrow$
(20)	R_1	$R_1 \searrow R_4 \nearrow$	R_5	No fault	R_1	$R_1 \nearrow R_2 \nearrow$	R_1	$R_1 \nearrow R_2 \nearrow R_4 \nearrow$	R_4	$R_1 \nearrow$
Diagnosis Ratio	100%	75%	0%	90%	75%	75%	65%	75%	25%	75%

Result1 and Result2 represent the diagnosis results using the method in [14] and this paper.

\nearrow represents the increase of element parameter; \searrow represents the decrease of element parameter; / represents the relation of OR.

From the diagnosis results shown in Table 3, compared with the method in [14], it can be seen that when R_1 is in each faulty state the method in this paper makes some progress in diagnosis.

1. When $R_1=1\Omega$ and the others element's parameter is changing under their influence of tolerance randomly, the circuit is without fault. The method in [14] is unable to determine the real state of the circuit. To such state, the diagnosis ratio using the method in this paper can attain 90%.
2. Seen from the property of the diagnosis results, the method in this paper is a quantitative diagnosis and it can roughly estimate the parameter perturbation. Meanwhile the method in [14] is a qualitative diagnosis and it only locates the faulty element.
3. From the compared result in the example, when the parameter change is minor, the diagnosis ratio of method in [14] is better. When the parameter change is larger, the diagnosis ratio of method in [14] is descending heavily. But, to all those faults in the CUT, the diagnosis ratio of the method proposed in this paper is high and steady.
4. In all misdiagnosis using the method in this paper, the non-faulty element is diagnosed wrongly as faulty one but the faulty element is not lost. But, in all misdiagnosis using the method given in [14], the non-faulty element is diagnosed wrongly as a faulty one and the faulty element is lost.

5. Conclusions

A new approach to locate single or multiple soft-faults in circuit is presented here. In this paper, a standard circuit sensitivity analysis at accessible nodes with nominal parameters is required to be performed to build the node-voltage incremental equation firstly. Then, a diagnostic strategy for analog circuits is formulated using FNLP with limited test nodes. The diagnosis result includes soft-fault identification of the circuits and the determination of the faulty elements.

The method in this paper, with acceptance of FNLP for evaluating the parameters deviations, both identifies the faulty elements and determines their parameters. From the solution of the equation, it enables us to state whether the actual parameters are within tolerance ranges or some components are faulty quantitatively.

Acknowledgment

The authors would like to thank Prof. Reny-Wen Liu of the University of Notre Dame, USA, for his constructive suggestions and guidance in this work. And the authors would like to thank the support of the Program for New Century Excellent Talents in University (NCET-05-0804) and the partial support of the Chinese National Programs for High Technology Research and Development (2006AA06Z222).

References

- [1] *Semiconductor Industry Technology Workshop Conclusions*, 1993, Semiconductor Industry Association.
- [2] *European Design and Test Conference Conclusions*, March 1996.
- [3] L. Ruy-Wen, V. Visvanathan: "Sequentially Linear Fault Diagnosis: Part I-Theory". *IEEE Trans. Circuits. Sys.*, vol. CAS-26, no.7, Jul. 1979, pp. 490–495.
- [4] J.W. Bandler, A.E. Salama: "Fault diagnosis of analog circuits". *Proc. of the IEEE*, vol. 73, no. 8, 1985, pp. 1279–1325.
- [5] J.W. Bandler, R.M. Biernacki, A.E. Salama: "A linear programming approach to fault location in analog circuits". *Proc. IEEE Int. Symp. Circuits and Systems*, Chicago, IL, 1981, pp. 256–260.

- [6] J.W. Bandler, R.M. Biernacki, A.E. Salama, J.A. Starzyk: “Fault isolation in linear analog circuits using the l_1 norm”. *Proc. IEEE Int. Symp. Circuits and Systems*, Rome, Italy, 1982, pp. 1140–1143.
- [7] C. Ahrikencheikh, M. Spears: “Limited access testing of analog circuits: handling tolerances”. *Proc. Int. Test Conference*, 1999, pp. 577–586.
- [8] G. Devarayanadurg, M. Soma: “Analytical fault modeling and static test generation for analog ICs”. *IEEE Int. Conf. on Computer-Aided Design*, San Jose, CA, 1994, pp. 44–47.
- [9] G. Devarayanadurg, M. Soma: “Dynamic test signal design for analog ICs”. *IEEE Int. Conf. on Computer-Aided Design*, San Jose, CA, 1995, pp. 627–630.
- [10] Y. He, Y. Sun: “Neural network-based L_1 -norm optimisation approach for fault diagnosis of nonlinear circuits with tolerance”. *Proc. IEEE on Circuits, Devices and Systems*, vol. 148, no. 4, Aug. 2001, pp 223–228.
- [11] M. Tadeusiewicz, S. Halgas, M. Korzybski: “An Algorithm for Soft-Fault Diagnosis of Linear and Nonlinear Circuits”. *IEEE Trans. Circuits Syst. I*, vol. 49, no. 11, Nov. 2002, pp 1648–1653.
- [12] I. Skrjanc, S. Blazic, O. Agamennoni: “Interval Fuzzy Model Identification Using l_∞ -Norm”. *IEEE Trans. Fuzzy Systems*, vol. 13, no. 5, Oct 2005, pp. 561–568.
- [13] L. Feng, W. Peng-Yung: “The Invariance of Node-Voltage Sensitivity Sequence and Its Application in a Unified Fault Detection Dictionary Method”. *IEEE Trans. Circuits Sys. I*, vol. 46, Oct 1999, pp.1222–1227.
- [14] W. Peng, Y. Shiyuan: “A New Diagnosis Approach for Handling Tolerance in Analog and Mixed-Signal Circuits by Using Fuzzy Math”. *IEEE Trans. Circuits Sys. I*, vol. 52, no. 10, Oct. 2005, pp. 2118–2127.
- [15] L. Zhou, Y. Shi, J. Tang, Y. Li: “Soft Fault Diagnosis in Analog Circuit Based on Fuzzy and Direction Vector”. *Metrol. Meas. Syst.*, vol. XVI, no. 1, 2009, pp. 61–75.
- [16] P. Jantos, D. Grzechca, J. Rutkowski: “Global Parametric Faults Identification in Analogue Electronic Circuits”. *Metrol. Meas. Syst.*, vol. XVI, no. 3, 2009, pp. 391–402.
- [17] L.A. Zadeh: “Outline of a new approach to the analysis of complex systems and decision processes”. *IEEE Trans. Syst., Man, Cybernetics*, vol. SMC-3, Jan. 1973, pp. 28–34.
- [18] F. Nagata: “First-order necessary optimality conditions in fuzzy nonlinear programming problems”. *Kyoto University Research Information Repository*, vol. 1068, Oct 1998, pp. 134–141.
- [19] M. Fares, B. Kaminska: “FPAD: A Fuzzy Nonlinear Programming Approach to Analog Circuit Design”. *IEEE Trans. Computer-aided Design of Integrated Circuits and Systems*, vol. 14, no. 7, Jul. 1995, pp. 785–793.
- [20] P. Zuzeng, S. Yunyu: *Fuzzy Math and Application*. 2nd ed., Wuhan University Press, 2007.
- [21] D.G. Luenberger: “Linear and nonlinear programming”. 2nd ed., Boston, London, Kluwer Academic, 2004.